

*Phoenix Display International, Inc.*

# PRODUCT PREVIEW

## 16 Character x 2 Line

### SPECIFICATIONS

#### MODULE

Part Number	C-160207S/C-VA
Format	16 Characters x 2 Lines
Controller	KS0066
Overall Dimensions	122.0mm x 44.0mm x 11.0/15.0mm
Active Area	94.8mm x 20.2mm
Character Size	4.8mm x 9.7mm
Pixel Size	920um x 1100um
Backlight System	None, EL or LED
Driver Attach	SMT/Chip on Board (COB)
Display Type	TN, STN, or FSTN
Duty	1/16
Disc	1/5

#### 1.0 DIMENSIONAL DRAWING

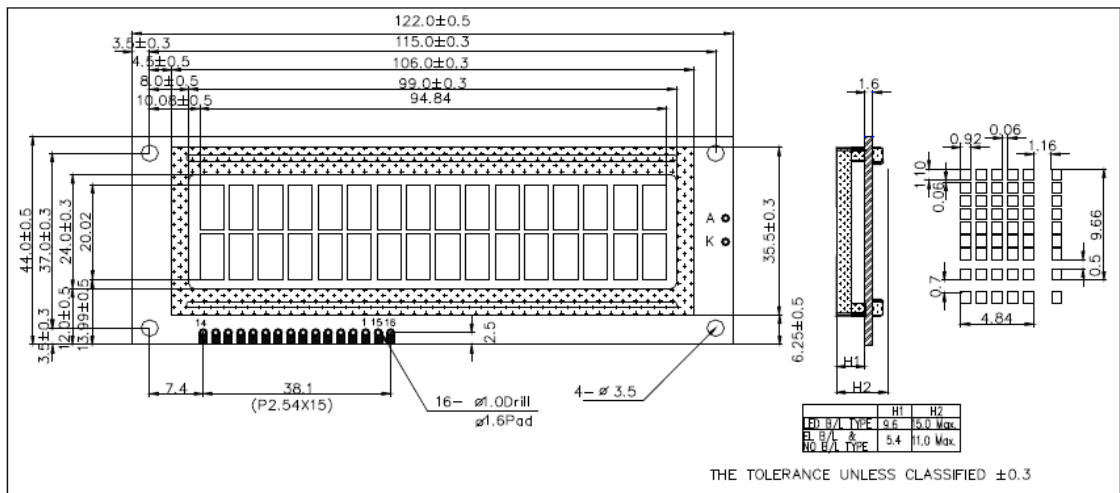

*Phoenix Display International, Inc.*

## PRODUCT PREVIEW

### 16 Character x 2 Line

#### 2.0 BLOCK DIAGRAM

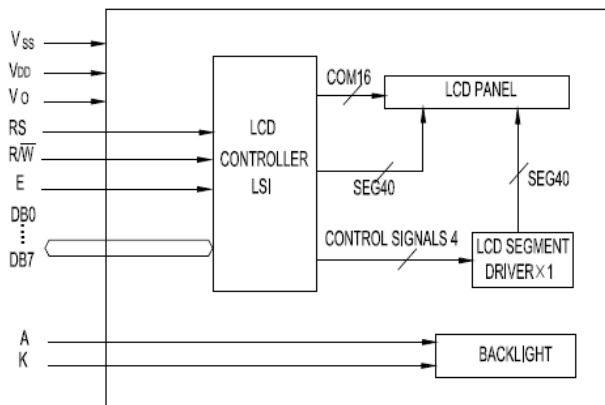

#### 3.0 PIN ASSIGNMENT

Pin no.	Symbol	Function
1	V <sub>SS</sub>	Power supply (GND)
2	V <sub>DD</sub>	Power supply(+)
3	V <sub>O</sub>	Contrast adjust
4	R <sub>s</sub>	Register select signal
5	R/W	Data read / write
6	E	Enable signal
7   14	DB0   DB7	Data bus line
15	A	LED+
16	K	LED-

#### 4.0 ELECTRICAL CHARACTERISTICS Ta=25 °C V<sub>DD</sub>=5.0V±0.25V

Item	Symbol	Test Condition	Standard Value				
			Min.	Typ.	Max.	Unit	
Power Supply Voltage	V <sub>DD</sub> -V <sub>SS</sub>	25°C	4.75	5.0	5.25	V	
LCD Operation Voltage	V <sub>OP</sub>	25°C	(STN)	-	5.0	-	V
			(TN)	-	5.0	-	V
LCM Current Consumption	I <sub>DD</sub>	25°C	-	2.0	3.0	mA	
Backlight Forward Voltage	V <sub>F</sub>	25°C	-	4.2	-	V	

#### 5.0 ABSOLUTE MAXIMUM RATINGS

Item	Symbol	Test Condition	Standard Value		
			Min.	Max.	Unit
Supply Voltage (Logic)	V <sub>DD</sub> -V <sub>SS</sub>	25°C	-0.3	7	V
Supply Voltage (LCD)	V <sub>DD</sub> -V <sub>O</sub>		V <sub>DD</sub> -13.5	V <sub>DD</sub> +0.3	V
Input Voltage	V <sub>IN</sub>		-0.3	V <sub>DD</sub> +0.3	V
Operating Temp.	T <sub>OPR</sub>		0	50	°C
Storage Temp.	T <sub>STG</sub>		-20	70	°C

