



PHOENIX DISPLAY INTERNATIONAL, INC.

PHOENIX DISPLAY INTERNATIONAL, INC SPECIFICATION FOR LCD MODULE

CUSTOMER	
PART NUMBER	PD0220042CMHX
DESCRIPTION	2.2" TFT 240 x 320
VERSION	1.0
ISSUE DATE	01-05-2013

COMPANY ADDRESS :
Phoenix Display International, Inc.
6150 W. Gila Springs Place, Unit 2
Chandler, AZ 85226
USA
www.phoenixdisplay.com
(630) 359-5700 office
(630) 359-5701 fax

Revision	Date	Description	Written By	Approved By
1.0	2013-1-5	New Release		

CONTENTS

- 1. General Features & Mechanical Specifications**
- 2. Outline Drawing**
- 3. Absolute Maximum Ratings**
- 4. Electrical Characteristics**
- 5. Interface Pin Connection**
- 6. Electro-optical Characteristics**
- 7. Standard Specification For Reliability**
- 8. Quality Assurance**
- 9. Precautions For using LCD Module**
- 10. Limited Warranty**
- 11. Important Notice**

1. General Features & Mechanical Specifications.

Item	Contents	Unit
LCD Type	a-Si TFT-color transmissive LCD	-
Display Format	RGB Stripe	-
Display color	262K color	-
Input Data	4-wire Serial interface	-
Viewing Direction	6 O'clock	-
Backlight	White(3x LED)	-
Driver IC	HX8367A	pixel
Resolution	240(RGB)x320	-
Dimensional outline	41.7(W)x56.16(H) x2.43(T)	mm
Active area	33.84(W) x 45.12(H)	mm
Pixel Pitch	47 (W)x 141(H)	Um
Diagonal length	2.2 "	inch
Operating Temp.	-20°C~ + 70°C	°C
Storage Temp.	-30°C~+ 80°C	°C

2. OUTLINE DRAWING

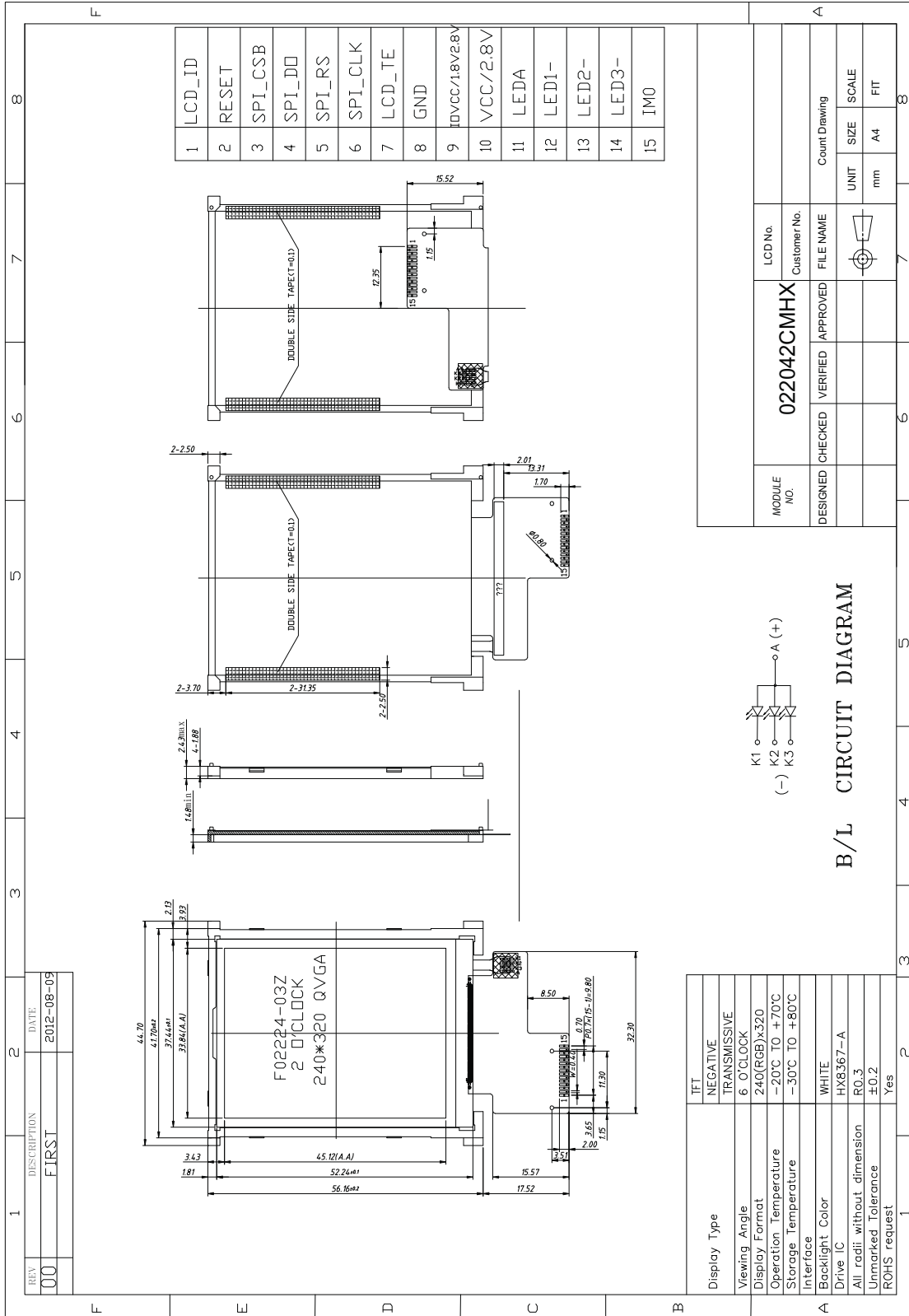

3. Absolute Mixmum Ratings(Ta=25°C)

Characteristics	Symbol	Min	Max	Unit	Remarks
Power supple voltage(1)	VCC	-0.3	4.6	V	(1),(2)
Power supply voltage(1)	VCI-GND	-0.3	+4.6	V	(1),(2)
Power supply voltage(1)	VGH-GND	-0.3	+18.5	V	(1)
Power supple voltage(1)	GND-VGL	-0.3	+18.5	V	(1)
Power supply voltage(1)	DDVDH	-0.3	+6.0	V	(1)

Note:

- (1) If the LSI is used above these absolute maximum ratings, it may become permanently damaged. Using the LSI within the following electrical characteristics limit is strongly recommended for normal operation. If these electrical characteristic conditions are also exceeded, the LSI will malfunction and cause poor reliability.
- (2) $V_{cc} \geq GND$ must be maintained.
- (3) $DDVDH \geq GND$ must be maintained.

3.1 Environmental absolute maximum ratings

ITEM	SPECIFICATION	REMARKS
Operating Temp.	-20 ~ 70 °C	Note(1)
Storage Temp.	-30 ~ 80 °C	Note (1) , (2)

Note:

- (1) 90% RH Max
- (2) In case of below 0°C, the response time of liquid crystal (LC) becomes slower and the color of panel becomes darker than normal one.

4. ELECTRICAL CHARACTERISTICS

4.1 DC characteristics

Item	Symbol	Condition	Min.	Typ.	Max.	Unit
Supply voltage	V_{CC}		2.6	2.8	3.0	V
Input voltage	H level (VIH)		0.8VCC	--	V_{CC}	V
	L level (VIL)		-0.3	--	$0.2V_{cc}$	V
Supply current	I_{cc}	Without LED VCC=2.8V	--	5	--	mA

4.2 DC characteristics of the LED back-light

$T_a = 25^{\circ}C$

Item	Symbol	Min.	Typ.	Max.	Unit
LED module Forward voltage	V_{LED}	3.0	3.3	3.5	V
LED module current	I_{LED}	--	45	--	mA
Luminance	L_v	3000	3200	--	Cd/m ²

Note: 3 LEDs in parallel of B/L module.

1 Test condition is:

a:Center point on active area

b:Best Contrast

2 Uniform measure condition:

a:Measure 9 point,Measure location is show below:

b:Uniform=(Min brightness/Max.brightness)x100%

c:Best Contrast.

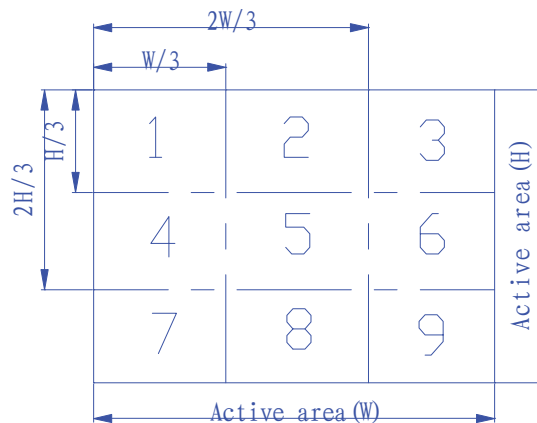

5 INTERFACE PIN CONNECTION

NO.	Symbol	Description
1	LCD_ID	NC
2	RESET	LCM reset pin
3	SPI_CSB	Chip selecting pin
4	SPI_DO	Serial data input pin in serial bus system interface.
5	SPI_RS	Data and command Pin
6	SPI_CLK	Serial data clock
7	LCD_TE	Tearing effect output.
8	GND	Ground
9	IOVCC	Power Supply(1.8V-2.8V)
10	VCC	Power Supply(2.8V)
11	LEDA	Anode input for Backlight
12	LED1-	Cathode input for Backlight
13	LED2-	Cathode input for Backlight
14	LED3-	Cathode input for Backlight
15	IM0	NC

6 ELECTRO-OPTICAL CHARACTERISTICS

No	Item	Symbol	Measuring Conditions		Min.	Typ.	Max.	Unit	Remark	
1	Response Time	Rise	Tr	$\theta = 0^\circ$ $\phi = 0^\circ$	25 °C		2	4	ms	Note (a)
		Fall	Tf	$\theta = 0^\circ$ $\phi = 0^\circ$	25 °C		6	12		
2	Viewing Angle (CR \geq 10)	θ		$\phi = 0^\circ$	25 °C	35	45	-	Deg	Note (b)
				$\phi = 180^\circ$	25 °C	35	45	-		
		θ	$\phi = 90^\circ$	25 °C	35	45	-			
			$\phi = 270^\circ$	25 °C	10	20	-			
3	Contrast Ratio	CR	-	25 °C		400	-	-	Note (c)	
4	Color of CIE Coordinate	White		X	25 °C	0.283	0.303	0.323	-	-
				Y	25 °C	0.305	0.325	0.345		
		Red	X	25 °C	0.606	0.626	0.646			
			Y	25 °C	0.314	0.334	0.354			
		Green	X	25 °C	0.257	0.277	0.397			
			Y	25 °C	0.529	0.549	0.569			
		Blue	X	25 °C	0.122	0.142	0.162			
			Y	25 °C	0.102	0.122	0.142			
5	Transmittance (without polarizer)	--	--	0 °C		16	-	%	-	

Note (a): Definition of Response Time

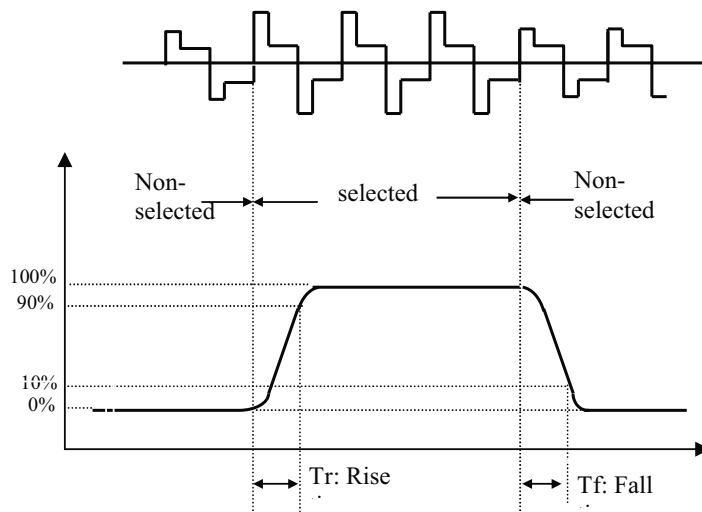

Note (b): Definition of Viewing Angle

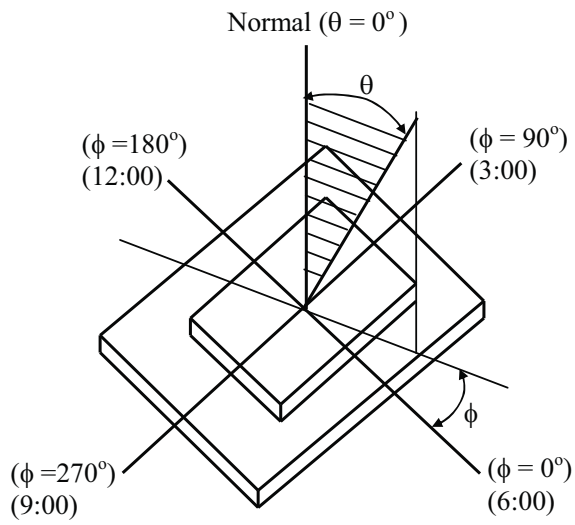

Note (c): Definition of Contrast Ratio

$$Cr = \frac{\text{Brightness of non-selected segment, } B2}{\text{Brightness of selected segment, } B1}$$

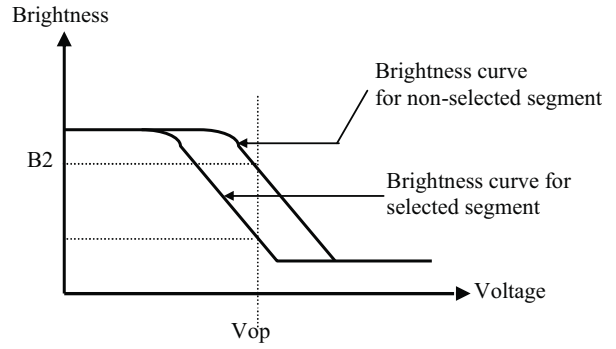

7 STANDARD SPECIFICATION FOR RELIABILITY

7.1 Standard specification of Reliability Test

No	Test Item	Content of Test	Test Condition	Applicable Standard
1	High temperature storage	Endurance test applying the high storage temperature for a long time.	7+/-3 °C 240 hrs	-----
2	Low temperature storage	Endurance test applying the low storage temperature for a long time.	-2+/-3 °C 240 hrs	-----
3	High temperature operation	Endurance test applying the electric stress (Voltage & Current) and the thermal stress to the element for a long time.	6+/-3 °C 240 hrs	-----
4	Low temperature operation	Endurance test applying the electric stress under low temperature for a long time.	-1+/-3 °C 240 hrs	-----
5	High temperature / Humidity operation	Endurance test applying the electric stress (Voltage & Current) and temperature / humidity stress to the element for a long time.	40 °C , 90 %RH 120 hrs	-----
6	Temperature cycle	Endurance test applying the low and high temperature cycle. $\begin{array}{c} -1^{\circ}\text{C} \xrightarrow{30\text{min.}} 25^{\circ}\text{C} \xrightarrow{5\text{min.}} 6^{\circ}\text{C} \\ \xleftarrow{30\text{min.}} \xleftarrow{5\text{min.}} \end{array}$ <p style="text-align: center;">1 cycle</p>	-1°C / 6°C 10 cycles	-----
Mechanical Test				
7	Drop Test	Endurance test applying the drop during transportation.	Packed, 100cm free fall (6 sides, 1 corner, 3edges)	----

7.2 Failure Judgment Criteria

After the reliability tests above, test sample shall be let return to room temperature and humidity for at least 4 hours before final tests are carried out.

Criterion Item	Failure Judgment Criteria
Electrical characteristic	Electrical short and open.
Mechanical characteristic	Out of mechanical specification
Optical characteristic	Out of the Appearance Standard

8 QUALITY ASSURANCE

8.1 Acceptable Quality Level (AQL)

Each lot should satisfy the quality level defined as follows:

- a) Inspection method: MIL-STD-105E Level II normal one time sampling
- b) AQL level

Category	AQL	Definition
Major	0.25%	Functional defective as product
Minor	1.00%	Satisfy all functions as product but not satisfy cosmetic standard

8.2 Cosmetic Screening Criteria

No	Defect	Judgment Criteria	Category	
1	Spots/Dust /Bubble (Round type)	Size, d (mm)	Acceptable quantity in active area	
		$d \leq 0.15$	Disregard	
		$0.15 < d \leq 0.20$	3	
		$d > 0.20$	0	
2	Spots/Dust /Bubble /Scratches (Line type)	Width, W (mm)	Length, L (mm)	Acceptable quantity in active area
		$W \leq 0.02$	Disregard	Disregard
		$W \leq 0.03$	$L \leq 1.0$	Disregard
		$W \leq 0.05$	$L \leq 2.0$	3
		$W > 0.05$	Disregard	0
3	Background color & Rainbow	Not to be noticeable.	Minor	
4	Allowable density	Above defects should be separated more than 30mm each other.	Minor	
6	Coloration	Not to be noticeable coloration in the viewing area of the LCD panels. Back-lit type should be judged with back-lit on state only.	Minor	
7	Rainbow	Not to be noticeable.	Minor	
8	Dot size	To be 95% ~ 105% of the dot size (Typ.) in drawing. Partial defects of each dot (ex. pin-hole) should be treated as 'spot'. (See <i>Cosmetic Screening Criteria (Operating) No.1</i>)	Minor	

Note: $d = (\text{long length} + \text{short length}) / 2$

9 PRECAUTIONS FOR USING LCD MODULE

9.1 Handling Precautions

- 9.1.1 The display panel is made of glass and polarizer. Do not subject it to mechanical shock by dropping or impact which may cause chipping especially on the edges.
- 9.1.2 Do not touch, push or rub the exposed polarizers with anything harder than an HB pencil lead (glass, tweezers, etc.). The polarizer covering the display surface of the LCD module is soft and easily scratched. Handle this polarizer carefully.
- 9.1.3 If the display surface becomes contaminated, breathe on the surface and gently wipe it with a soft dry cloth. If it is heavily contaminated, moisten cloth with Isopropyl alcohol or ethyl alcohol. Avoid using solvents like acetone (ketene), water, toluene, ethanol to clean the polarizer surface.
- 9.1.4 Please keep the temperature within specified range for use and storage. Polarization degradation, bubble generation or polarizer peel-off may occur with high temperature and high humidity.
- 9.1.5 Do not apply excessive force to the display surface or the adjoining areas since this may cause the color tone to vary.
- 9.1.6 Install the LCD Module by using the mounting holes. When mounting the LCD module make sure it is free of twisting, warping and distortion.
- 9.1.7 Exercise care to minimize corrosion of the electrode. Corrosion of the electrodes is accelerated by water droplets, moisture condensation or a current flow in a high-humidity environment.
- 9.1.8 NC terminal should be open. Do not connect anything.
- 9.1.9 If the logic circuit power is off, do not apply the input signals.
- 9.1.10 Avoid contacting oil and fats.
- 9.1.11 Condensation on the surface and contact with terminals due to cold will damage, stain or dirty the polarizers. After products are tested at low temperature they must be warmed up in a container before coming in contact with room temperature air.
- 9.1.12 Wipe off saliva or water drops immediately, contact with water over a long period of time may cause deformation or color fading.

9.2 Electro-Static Discharge Control

- 9.2.1 Since this module uses a CMOS LSI, the same careful attention should be paid to electrostatic discharge as for an ordinary CMOS IC.
- 9.2.2 Be sure to ground the body when handling the LCD modules. Tools required for assembling, such as soldering irons, must be properly grounded.
- 9.2.3 To reduce the amount of static electricity generated, do not conduct assembling and other work under dry conditions. To reduce the generation of static electricity, be careful that the air in the work is not too dried. A relative humidity of 50%-60% is recommended.
- 9.2.4 The LCD module is coated with a film to protect the display surface. Exercise care when peeling off this protective film since static electricity may be generated.
- 9.2.5 When soldering the terminal of LCM, make certain the AC power source for the soldering iron does not leak.

9.3 Precaution for soldering to the LCM

- 9.3.1 Observe the following when soldering lead wire, connector cable and etc. to the LCD module.

9.4 Soldering iron temperature: $300 \pm 10^{\circ}\text{C}$.

- 9.4.1 Soldering time: 3 sec.
- 9.4.2 Solder: eutectic solder.
- 9.4.3 If soldering flux is used, be sure to remove any remaining flux after finishing to soldering operation. (This does not apply in the case of a non-halogen type of flux.) It is recommended that you protect the LCD surface with a cover during soldering to prevent any damage due to flux spatters.

9.5 Precautions for Operation

- 9.5.1 Viewing angle varies with the change of liquid crystal driving voltage (V_O). Adjust V_O to show the best contrast.
- 9.5.2 Driving the LCD in the voltage above the limit shortens its lifetime.
- 9.5.3 Response time is greatly delayed at temperature below the operating temperature range. However, it will recover when it returns to the specified temperature range.
- 9.5.4 If the display area is pushed hard during operation, the display will become abnormal. However, it will return to normal if it is turned off and then back on.
- 9.5.5 When turning the power on, input each signal after the positive/negative voltage becomes stable.

9.6 Storage

- 9.6.1 When storing LCDs as spares for some years, the following precautions are necessary.
- 9.6.2 Store them in a sealed polyethylene bag. If properly sealed, there is no need for desiccant.
- 9.6.3 Store them in a dark place. Do not expose to sunlight or fluorescent light, keep the temperature between 0°C and 35°C .
- 9.6.4 Environmental conditions:
- 9.6.5 Do not leave them for more than 168hrs. at 60°C .
- 9.6.6 Should not be left for more than 48hrs. at -20°C .

9.7 Safety

- 9.7.1 It is recommended to crush damaged or unnecessary LCD into pieces and wash them off with solvents such as acetone and ethanol, which should later be burned.
- 9.7.2 If any liquid leaks out of a damaged glass cell and comes in contact with the hands, wash off thoroughly with soap and water.

10. Limited Warranty

PDILCD modules are not consumer products, but may be incorporated by PDI's customers into Consumer products or components thereof. PDI does not warrant that its LCD's and Components are fit for any such particular purpose.

1. The liability of PDILCD is limited to repair or replacement on the terms set forth below.
PDI will not be responsible for any subsequent or consequential events or injury or Damage to any personnel or user including third party personnel and / or user.
Unless otherwise agreed in writing between PDILCD and the customer, PDI will only Replace or repair any its LCD which is found defective electrically or visually when Inspected in accordance with PDI LCD acceptance standards for a period of three Months from the date of shipment. Confirmation of such date shall be based on freight Document.
2. No warranty can be granted if any of the precautions stated in LCD modules above have been disregarded. Broken glass, scratches on polarizers, mechanical damages as well as Defects that are caused by accelerated environmental tests are excluded from warranty.
3. In returning the LCD modules, they must be properly packaged and there should be detailed Description of the failures or defects.

11. Important Notice

The information presented in this specification has been carefully checked and is believed to be Accurate, however, no responsibility is assumed for inaccuracies, PDILCD reserves the right to Make changes to any specifications without further notice for performance, reliability, production Technique and other considerations, PDI does not assume any liability arising out of the Application or use of products herein. Please see Limited Warranty in the previous section.